

THE CAVE



Created to produce an infinite corridor, **THE CAVE** is a black and white back projection mapping installation that explores the ways in which the perspective can be seen and visualised.

With the simplicity of just few edges, **THE CAVE** drags the audience on an impressive journey, from a peaceful state through a dubstep chaos.

THE CAVE, featured at the Creative Review Annual Launch Party (Shoreditch, London) and at Mira Festival (Barcelona) has been created by Nicola Gastaldi, a motion graphics designer working full time at The Studio at Smoke & Mirrors, London.



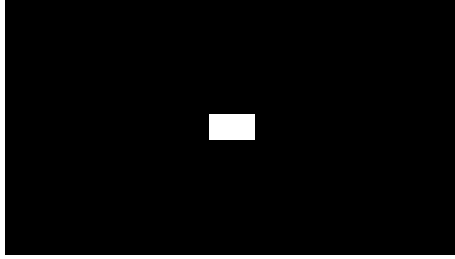

THE CAVE

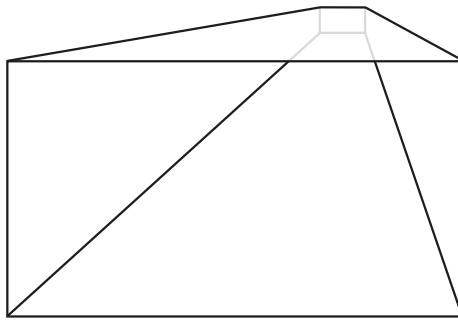

THE CAVE is a custom built acrylic reversed truncated pyramid hung from the ceiling of a dark room, approx. 6 sqm minimum. A small projector, usually a 3K, sits about 2 meters away from THE CAVE and back project the light onto it. The media player is one of the smallest on the market. THE CAVE works with speakers or with 5 headphones.